



iTehLab d.o.o.
informacijske tehnologije

www.itehlab.si

www.3D-tisk.si

www.facebook.com/3D.TISK.ZA.VSE

info@itehlab.si

info@3d-tisk.si

Tehnologije 3D-tiska

Uporabo

Ciljno nalaganje

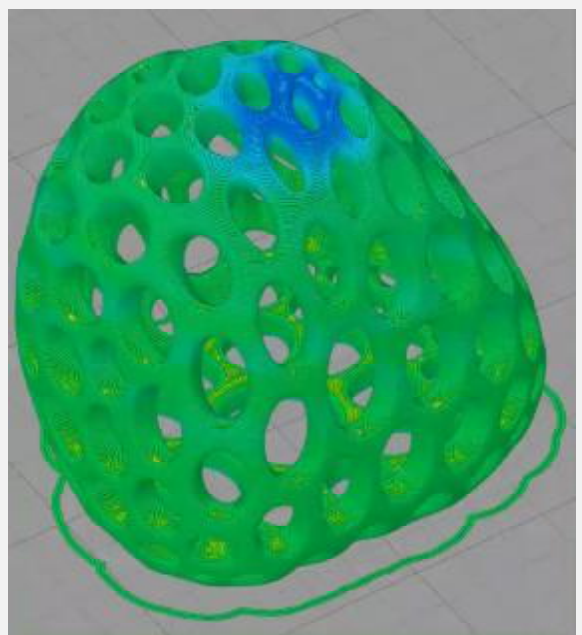
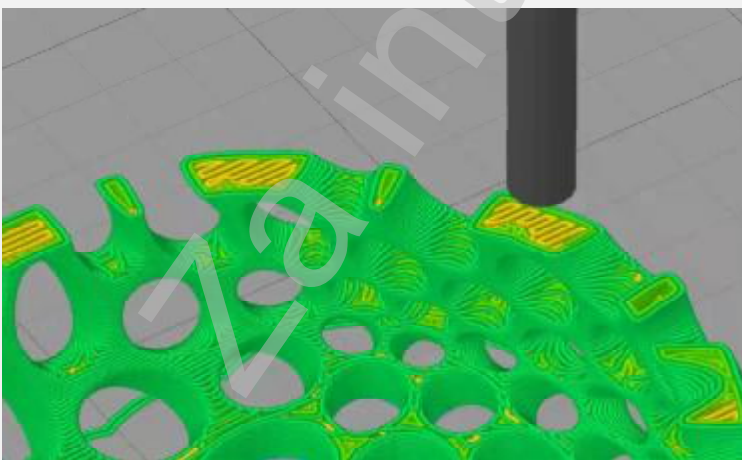

Ciljno nalaganje

- ✓ Poceni
- ✓ Hitro
- ✓ Enostavno
- ✓ Širok izbor materialov



Materiali

PLA

- Na osnovi obnovljivih virov



ABS

- Odporen na udarce



Najlon

- Trden in elastičen



HIPS

- Mehanska odpornost
- Podobne mehanske lastnosti kot ABS



PETG

- Visoka trdnost in natančnost tiska



TPE

- Elastičen material



Les

- Mešanica recikliranega lesa (40%) in neškodljivih polimerov



Kamen

- Mešanica fino zmlete krede in neškodljivih polimerov



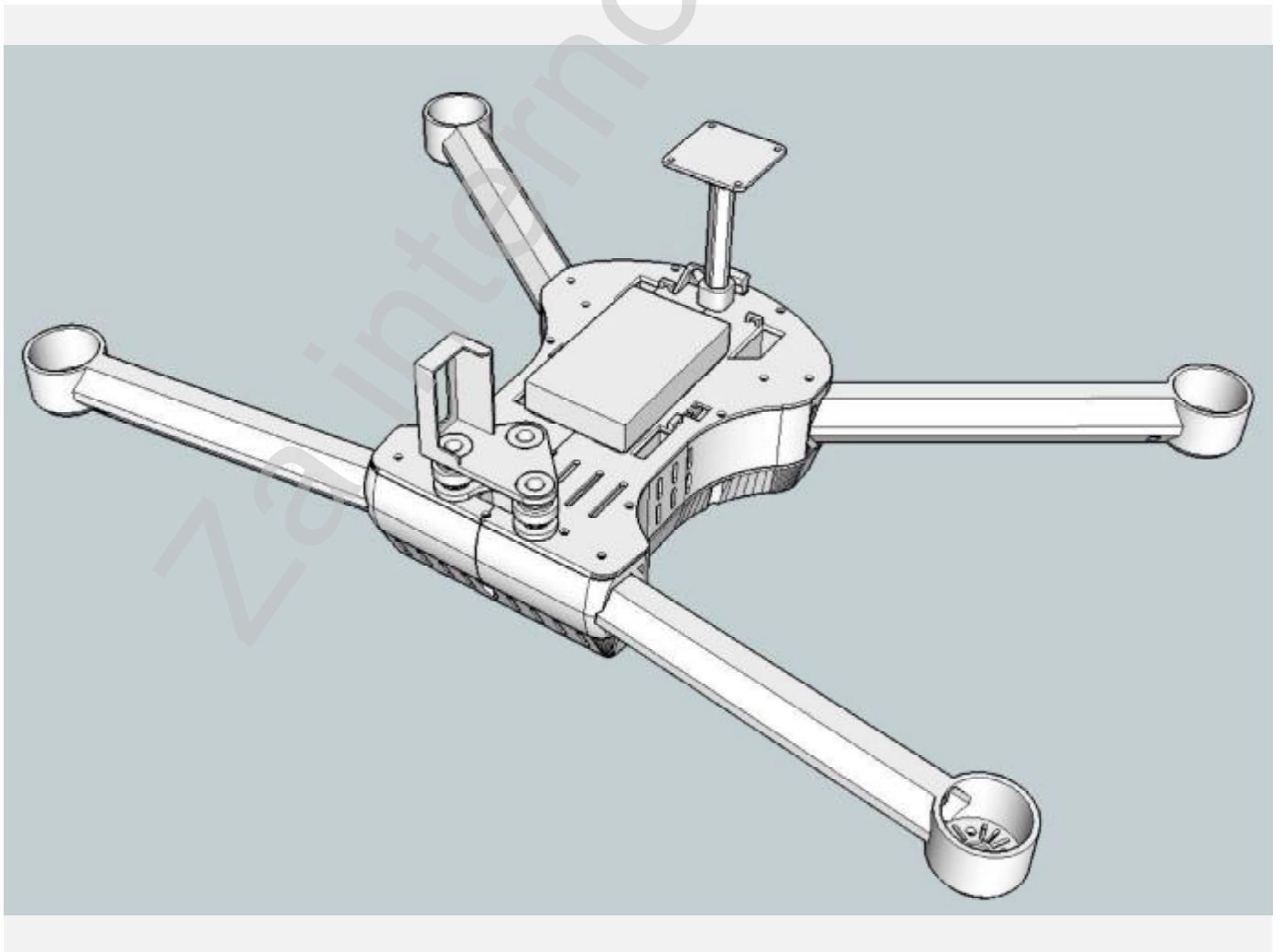

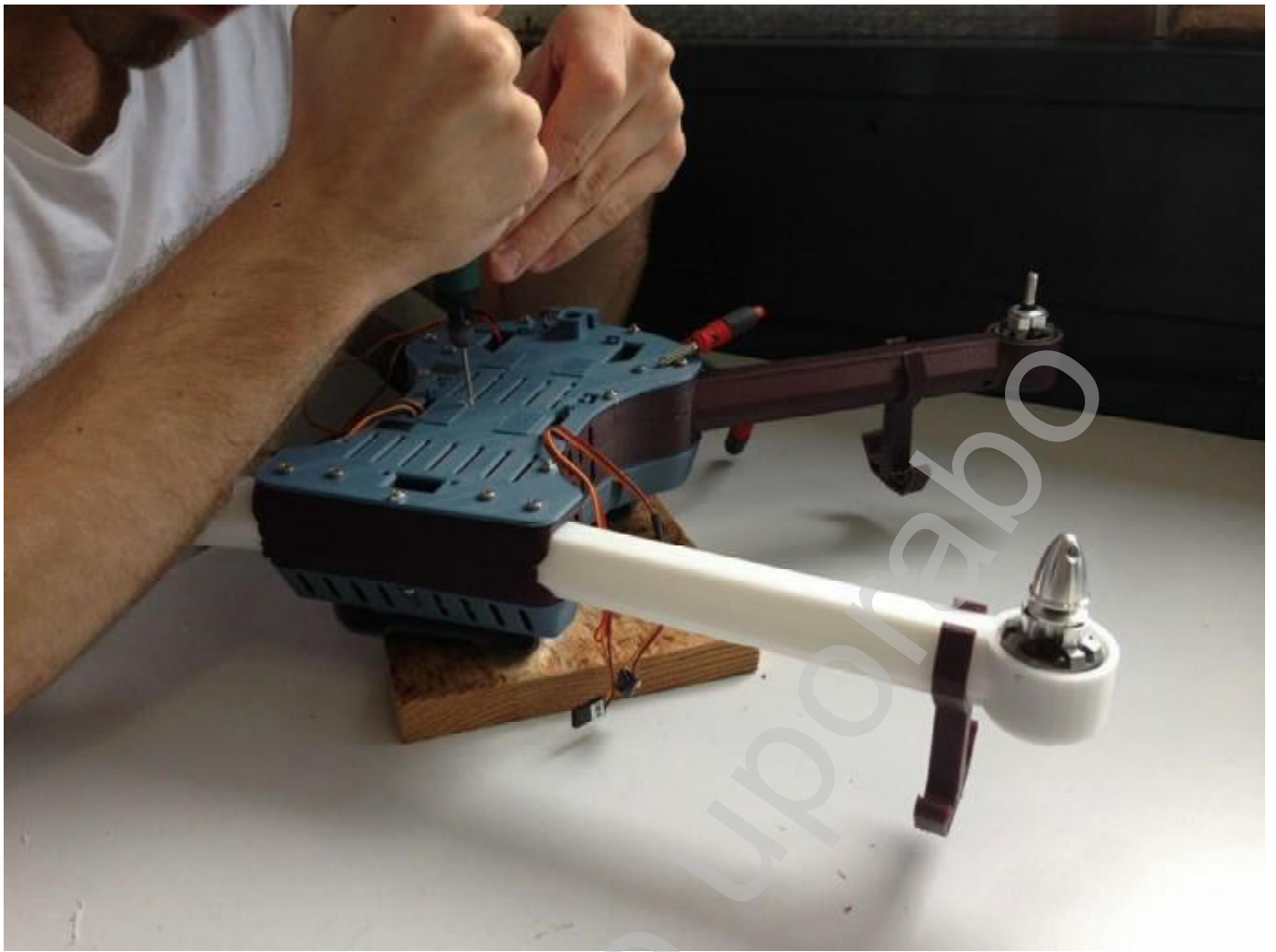



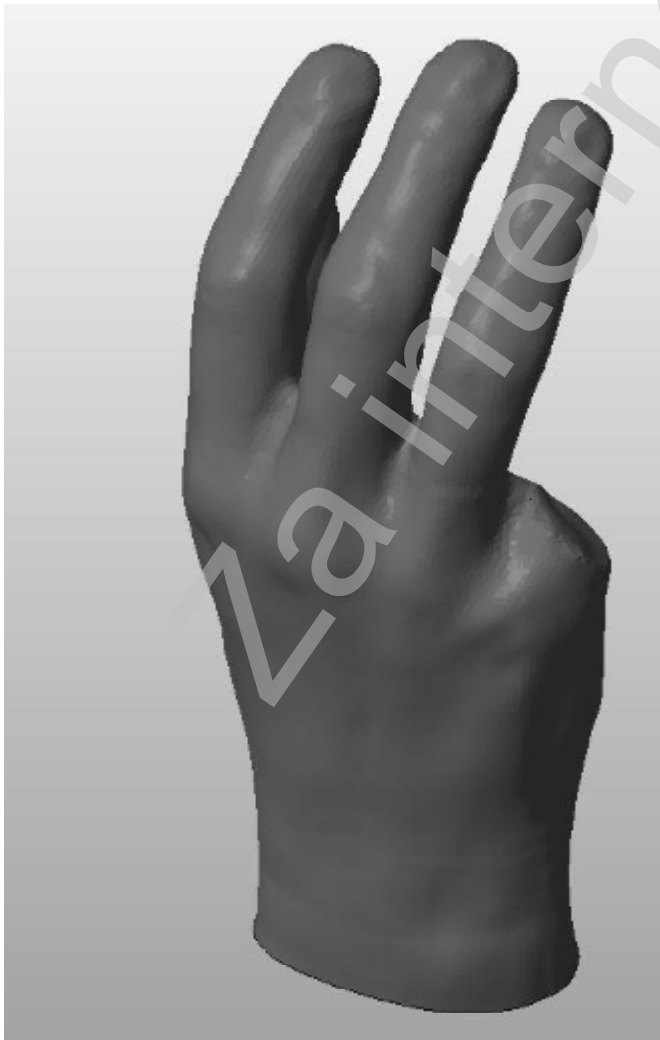



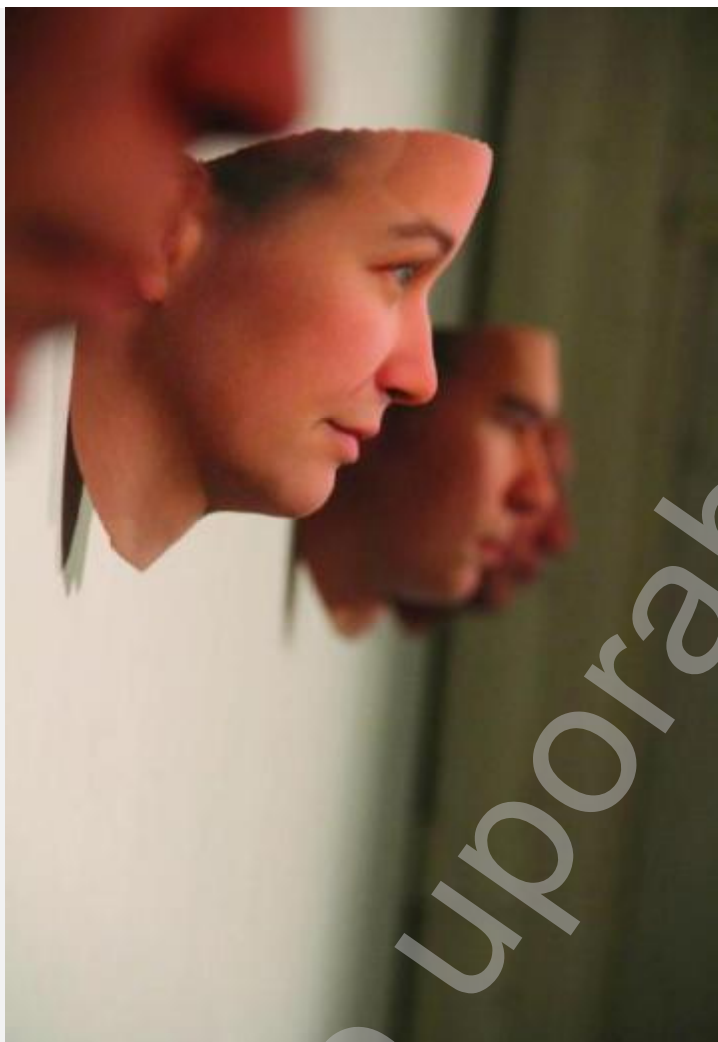

McorArke 



LOM – laminacija pol

- ✓ Barvni tisk (1M+ barv)
- ✓ Enostavna uporaba
- ✓ Zanesljivost
- ✓ Nizki stroški
- ✓ Hitra izdelava









3d-tisk.si

Za interno uporabo